

GSE

Economical Granulators



ZERMA



GSE 300/300



GSE 300/600



GSE 500/500



GSE 700/1200



The GSE economical granulator series are the ultimate value for money machines. The completely welded cutting chamber in conjunction with the "V" type rotor design ensures dependability in operation and universal applications use. The cutting geometry of the GSE series allows material feed injection even with voluminous types of material. The complete GSE series line achieves a high quality granulate independent of the material such as injection moulded parts, blow moulded parts, profiles, sheet, film, etc. The GSE series is very economically priced, reliable, easy to clean and ensures a dependable operating unit.

Compact Economical Granulators



Simplified Knife Adjustment:

Knife adjustment is performed totally outside the granulator prior to installation with the assistance of a knife adjustment fixture that is provided with the machine. The rotor and stator knives are manufactured from a high tensile strength steel and can be resharpened numerous times.



Mobile Compact Design:

The whole unit mounted on a single baseframe creates a compact and mobile design. The granulator can be moved or transported with a fork lift or standard lifting device.

Unique Cutting Geometry:

The rotor knives are designed with the latest "V" cut technology. In comparison to the standard full angled knives, the "V" cut design creates a consistent material cutting concentration toward the middle area of the rotor for the ultimate size reduction. The "V" cutting configuration reduces knife wear and eliminates excessive cutting chamber side wall wear.



Material Drawer:

The machines are equipped with a stainless-steel material drawer to collect the ground infeed materials. Optionally, the GSE series can be equipped with a suction trough and blowing station.



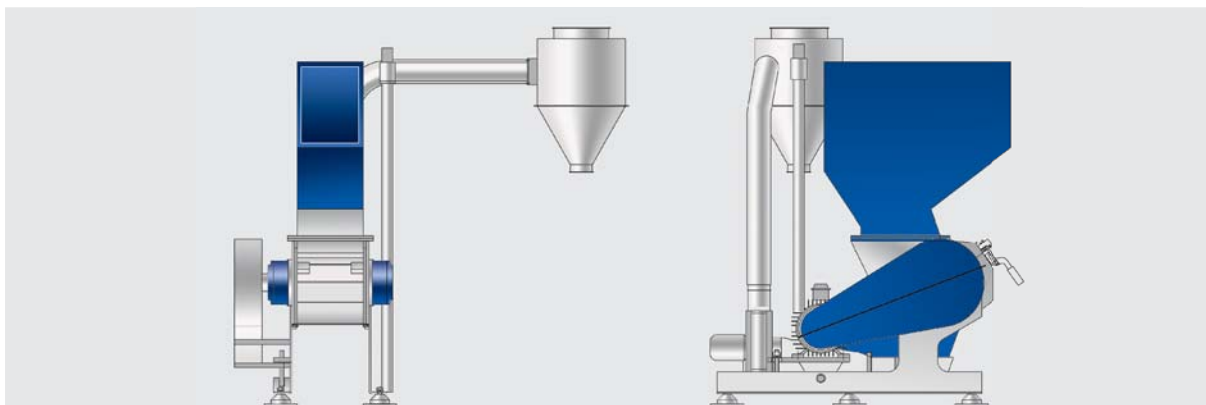

| Type GSE | Rotor diameter (mm) | Rotor width (mm) | Feed opening (mm) | Drive capacity (kW) |
|------------|---------------------|------------------|-------------------|---------------------|
| 200 / 200 | 200 | 200 | 300 x 190 | 4 - 5.5 |
| 200 / 400 | 200 | 400 | 300 x 390 | 4 - 7.5 |
| 300 / 300 | 300 | 300 | 400 x 290 | 5.5 - 11 |
| 300 / 600 | 300 | 600 | 400 x 590 | 11 - 18.5 |
| 300 / 1000 | 300 | 1000 | 400 x 990 | 18.5 - 22 |
| 500 / 500 | 500 | 500 | 560 x 500 | 22 - 37 |
| 500 / 700 | 500 | 700 | 560 x 700 | 30 - 45 |
| 500 / 1200 | 500 | 1200 | 560 x 700 | 37 - 55 |
| 700 / 700 | 700 | 700 | 720 x 700 | 30 - 55 |
| 700 / 1200 | 700 | 1200 | 720 x 1200 | 45 - 75 |

subject to technical modification

www.zerma.com

Please contact your nearest sales office

China:

Zerma Machinery & Recycling Technology (Shanghai) Co., Ltd.
5 Xinjie Rd XinQiao Township Ind. Park, Songjiang Shanghai, Zip: 201612, China
Phone: +86 21 57645573
Fax: +86 21 57646766
info@zerma.com · www.zerma.com

Germany / Europe:

ZERMA Zerkleinerungsmaschinenbau GmbH
Am Leitzelbach 23
74889 Sinsheim-Dühren
Germany
Phone: +49 7261 9156-0
Fax: +49 7261 3556
info@zerma.de · www.zerma.de

USA:

Econo-Grind USA
3000 Turner Street
South Attleboro, MA 02703 - 7900
USA
Phone: +1 508 399-3018
Fax: +1 508 399-3150
info@econogrind.com · www.econogrind.com

South-East-Asia:

ZERMA (Thailand) Co., Ltd.
78/6 Moo 7 Kingkaew Road, Rachatewa, Bangplee, Samutprakarn 10540
Thailand
Phone: +66 2 738 5056-7
Fax: +66 2 738 5058
info@zerma.co.th · www.zerma.co.th

GB / Ireland:

ZERMA UK Ltd. (Richard Monkhouse)
27 Weaver Park Est
Mill Lane, Frodsham, Cheshire WA6 7JH
England
Phone: +44 1928 734724
Fax: +44 1928 734725
info@zerma.co.uk · www.zerma.co.uk

Your dealer:

Subject to technical modifications Version 07/04 1 0